

WYOMING CENTRAL SCHOOL DISTRICT

NOVEMBER / DECEMBER 2023



From the Desk of the Superintendent

Wyoming CSD Families,

I am excited and happy to welcome you back to another school year! It is always so much better when our halls are filled with students and staff! We have certainly been very busy these first few months with learning, extracurricular activities, field trips, and so much more. Thank you to our staff for creating opportunities for our students and congratulations to our fall athletes and coaches on their successful fall season. As we move into the next season, I am excited to get into the classrooms and celebrate our students in all that they are involved in!

I want to thank our PTO for supporting our field trip opportunities as well as hosting the most recent Trunk or Treat.

It was a great family event and we couldn't have done it without the support of our PTO parents and staff! If you didn't have the chance to check it out, make sure you add it to your calendar for next year!

Community involvement has the potential to enrich the lives of our students and help overcome potential obstacles in their way. This involvement can provide social connections, friendships, and positive support for our students. It is for these reasons we are bringing back some traditions that we haven't seen in a (Office of the Aging Luncheon, Holiday Luncheon). With the help of our community we are excited to be bringing some of these traditions back to Wyoming

as well as embracing new traditions. Your input and continued partnership in your child's educational experience is crucial to their success. Please continue to utilize ParentSquare as a means to communicate with us here and keep track of the great happenings here at Wyoming Central School.

I look forward to seeing you at our upcoming school events!

All my best to you and your family,
Sincerely,

Emily Herman
Superintendent of School

No School for Wyoming Central Students

December 25th – January 1st
January 15th
January 27th

Winter Recess
Martin Luther King, Jr.
Early Dismissal Day

Important Dates to Add to Your Calendar

Please mark your calendars and make every attempt to have your child attend school on these dates:

12/5 Winter Concert (Kindergarten – 4th Grade)
12/7 Winter Concert (Middle School Band and Chorus)

Emergency Closing Information

In the event the roads are deemed impassable due to weather conditions, the Superintendent shall have the authority to close the school until the conditions are improved. An Emergency Outreach message will be sent to all families with students in the District at the earliest time possible. Furthermore, any school closings or delayed starts will be posted on the school website's main page...www.wyomingcsd.org

Local television stations will still broadcast school closing or delays. These stations are as follows...

Channels 2, 4, 7, 8, 10, 13 and R News

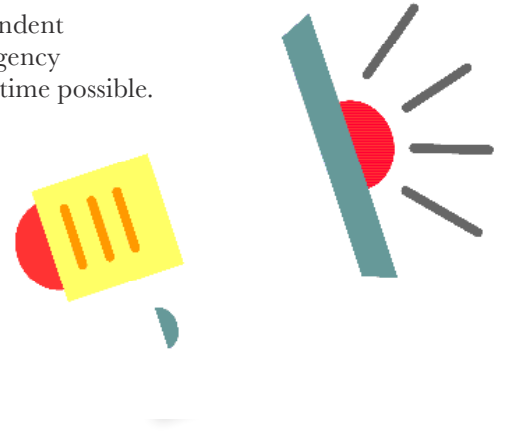

Vehicles on School Grounds

Our Board of Education has had a long-standing policy prohibiting motorized vehicles on grounds and fields. During the winter, this policy applies to snowmobiles and other recreational vehicles.

Snowmobiling can be great fun when done in a safe area. There are a number of obstacles that could cause serious injury to somebody using a snowmobile on school property. Bleachers, soccer goals, back stops, fences are just a few items. We ask you support with a concern for your safety. PLEASE no snowmobiling on school property.

Homework Request

If your child(ren) is/are absent from school and you would like their schoolwork, please let the school nurse know when you are calling regarding the absence. Please make the request by 9:30 a.m. This will enable teachers to get the work ready to be picked up in the afternoon or given to a sibling here at the school. Thank you.

Address or Phone Number (home and cell) Change?

Please keep the school office up-to-date on your contact information, including address, phone number (including cell phone numbers) and email address. There are times when the school may need to contact you (sick child, emergency, homework, etc.)

From the Transportation Department

Please call the Bus Garage at (585)495-6560, if your child will NOT be riding the bus. You may call at any time and leave a message.

School Bus Rules to Follow:

- No cell phones turned on – NO EXCEPTIONS – Keep in bag, turned off
- Keep aisles and exits free of obstacles
- Obey Bus Driver – Bus Driver may assign seats
- Be respectful to other riders
- Stay in seat, talk quietly. No profane language
- Keep head, hands and feet inside bus
- NO Food or Drink
- Keep bus clean. Do not cause damage to bus or equipment
- No pets, animals, flammable material, or large items on bus



Mandated Requirements for Picking up Students

Pursuant to the school's Insurance Carrier the following policies must be adhered to when a child is picked up at school:

- Students will be released only to the parent/guardian or those family members or adults who are designated on the student's [registration record] [emergency release form] [any form used by the school for the purpose of release a child].
- If an individual other than the child's parent or legal guardian (listed on the registration record) seeks to pick up a child from school prior to the end of the school day, the individual must present a parent note, doctor's appointment note, court appearance summons or other certified check out, in addition to the fact that the individual must be listed on the list of those persons authorized to pick up the child.
- In addition, the note must have a phone number whereby the [student's] parent can be reached by an administrator for verification.
- Children cannot leave school grounds until the authorized person has signed them out at the school office.
- Staff members assigned to release students to pick up by an authorized person are required to request and review valid (i.e., still current) picture identification.
- Students are to be released early only upon approval of the principal or his/ her designee.
- The principal shall not honor a telephone request for a student's early dismissal to someone not listed on the emergency card
- Parents/guardians of all students will be reminded no later than the end of the first week of school to update registration information.
- Parents/guardians of all students are notified at least twice that they must inform the school immediately if there is any change of emergency information, or, in particular, those individuals authorized to pick up their child(ren)
- In all cases, the person picking up a child from school must sign a log indicating that they have picked up the child, noting the date and time.
- Parents! Guardians shall be notified that, if a student will be picked up by an individual not listed on the student's registration form, the parent should notify school officials in person or writing along with the date, pick-up time and relationship of the person to the family (i.e., uncle, cousin, neighbor, etc.). The person should be prepared to show a driver's license or other form of photo I.D. If the person will be picking up the child occasionally, the parent should add the name of the person to the registration form.
- Parents/ guardians shall be notified that it is their responsibility to provide legal documents, when applicable, restricting access to a student by an individual. If a person who checks into the office to pick up a child is not on the list of persons authorized to do so, staff members must check the student's file to determine if there is any

document restricting release. Staff members are charged with the knowledge that a student must not be released to an unauthorized individual if the school has on file any document restricting release. Under no circumstances shall staff knowingly release students to individuals who have been prohibited from having contact with children or a parent who has been legally denied access to the student or access to a school site.

- All requests to pick up a child from school shall be kept on file.

District Wide School Safety & Health Emergency Plan & AHERA

The following is information for all school employees, parents, and interested persons regarding the District Wide School Safety and Health Emergency Plan (Emergency Response Plan) and AHERA Compliance Activities:

The Wyoming Central School has developed a District Wide School Safety and Health Emergency Plan as required by New York State Law. This plan will be used to guide our responses during emergencies, which involve our school, students and staff.

The purpose in having such a plan is to inform those who might be involved in such responses of their responsibilities, so that actions can be coordinated and flow smoothly. Ultimately, the plan is for the purpose of protecting our students, staff and anyone else who might be involved in any emergency situations involving our school.

As a public document, the Emergency Response Plan is available on the school website as well as in the District Office for anyone who may wish to review it.

In addition to having the plan, there will be at least one drill during the school year for the purpose of practicing and evaluating the procedures in it.

AHERA

AHERA is a federal law enacted in 1987, which requires all school districts to re-inspect facilities for asbestos containing building materials.

Our facilities have been inspected and response actions are planned to insure a continued safe environment for our students and employees. Activities include training of maintenance staff to prevent disturbance of asbestos and periodic reinspection and surveillance activities by trained personnel.

Details of such activities are described in the district's AHERA Management Plan, which is available for your review in the District Office.

If you have any questions or concerns in this regard feel free to contact the school at 495-6222.

Pesticide Notice

New York State Education Law Section 409-H, effective July 1, 2002, requires all public and non-public elementary and secondary schools to provide written notification to all persons in parental relation, faculty, and staff regarding the potential use of pesticides periodically throughout the school year.

The Wyoming Central School District is required to maintain a list of persons in parental relation, faculty, and staff who wish to receive 48-hour prior written notification of certain pesticide applications. The following pesticide applications are not subject to prior notification requirements:

- A school remains unoccupied for a continuous 72-hours following an application;
- Anti-microbial products
- Nonvolatile rodenticides in tamper resistant bait stations in areas inaccessible to children;
- Nonvolatile insecticidal baits in tamper resistant bait stations in areas inaccessible to children;
- Silica gels and other nonvolatile ready-to-us pastes, foams, or gels in areas inaccessible to children;
- Boric acid and disodium octaborate tetrahydrate;

- The application of EPA designated biopesticides;
- The application of EPA designated exempt materials under 40CRF152.25;
- The use of aerosol products with a directed spray in containers of 18 fluid ounces or less when used to protect individuals from an imminent threat from stinging and biting insects including venomous spiders, bees, wasps, and hornets.

In the event of an emergency application necessary to protect against an imminent threat to human health, a good faith effort will be made to supply written notification to those on the 48-hour notification list.

If you would like to receive 48-hour notification of pesticide applications that are scheduled to occur in our school, please complete the form below and return to:

Superintendent's Office
Wyoming Central School District
PO Box 244
Wyoming, NY 14591-0244

Wyoming Central School District

Request for Pesticide Application Notification

Date _____

I am the parent (or guardian) of _____

who attend(s) Wyoming Central School in the following grades: _____

Please consider this my formal request to be placed on the list to receive pesticide notices and information.

All notices are to be mailed to the following address: *(Please Print Clearly)*

Name _____

Street Address or Post Office Box _____

City _____ State _____ Zip _____

I can be reached by telephone at the following numbers:

Daytime _____ Evening _____

Sincerely, _____

Kindergarten News

By Mrs. Forti

It is hard to believe we are back in the full swing of things. We hope you were able to check out our scarecrow at Apple-Umpkin. It was all about what we want to be when we grow up. Kindergarten is off to a wonderful start with learning “all about me”, apples, new school procedures, friends and families. Having done a taste test with three different colored apples, we found that we liked RED best. We are discovering and writing numbers 0-5. We are looking forward to some trips to a farm and possibly the Wyoming Free Library. We are starting to build a great little community here in our class. Looking ahead we are super excited about Fire Prevention week and Halloween.



The Wonderful Pre-K Class

By Mrs. Czworka and Ms. Theresa

We are so fortunate to have a full day Pre-K Class. The Pre-K Class is having a great start of the year with 15 wonderful students. Our morning starts with a mystery question and free play. We then go into our opening group that consist of calendar, weather, share the news, message of the day, and then our centers. We have play centers daily that the students truly enjoy and get to choose where they want to play. The centers are dramatic play, blocks, science, table toys, art, and literacy.

The students have enjoyed painting handprints and fingerprints, tearing paper, playing with play dough and coloring. We have made apples, pumpkins, bats, and spiders. It was so nice to go on a field trip to the Chamberlain Farm. We were able to get up close to the farm equipment, pet and feed calves, milk a cow, have cheese sticks and an apple, drink milk, and also we were able to get a coloring book to color. Thank you to the Chamberlains for a great time. We continue to have lots of fun times in the classroom and in music, art, gym, and library. All of us have made lots of new friends that we play with and are being kind to. We look forward to more days of learning and having fun!



Fabulous First Grade

By: Mrs. Romasser, Teacher

So much FUN and LEARNING is taking place in Mrs. Romasser's First Grade class!

We have worked hard on learning and following the First Grade rules and procedures. We have participated in read-aloud stories, such as "No, David" and "Have You Filled A Bucket Today?", to support our learning. We have even acted out different scenarios to role play what it looks like/sounds like/ feels like to make good choices (and what to do if someone around you makes a bad choice).

Our class made an Albert Einstein scarecrow, which was displayed in front of the school during Apple-Umpkin. A special thank you goes out to Miss Shari, Mrs. Maria Herman, First Graders, and their families for all of their ideas, materials, and hard work in putting our scarecrow together!

We had the opportunity to take a fun field trip to Chamberlain's farm! Thank you to the Chamberlain family for hosting us, providing treats, and teaching us about agriculture. It was a beautiful day, and we all really enjoyed ourselves!

We are all looking forward to spending the next few months together, learning and growing in First Grade!



Second Grade News

By: Ms. Santullo, Teacher

We have been doing a lot of fun things since the start of the new year. Here are just a few pictures of the things we have been busy doing.



Fun in the 4th Grade

By: Students — Natalie Meeder and Abby Palmer

The first day of school the class had a great day. As the month has gone by, fourth grade has been doing a lot of activities. We did a couple of science experiments like natural disasters. We are all starting new reading levels. We go out almost every day but now that it is getting colder we are less able to go outside. The kiddos are working hard on starting their personal narratives. The class is working on regrouping in math. We are all so excited for the big field trip coming up this Friday, featuring the Genesee Country Village Museum we printed copy of maps for the class. Everybody is doing well in specials, they are so excited for instruments that we are starting next week. We are having so much fun with this amazing class. The class is doing wonderful and we are in fourth grade with all the kiddos.



Fifth Grade Happenings

By: Mrs. Lamar, Teacher

Fifth grade is off to a fantastic start this year, as always! Students have begun the year by learning what it takes to be the most amazing fifth grader they can be. They have had a preview of all the different topics that they will be learning about this year and the different experiences that they will have, including field trips!

One particularly exciting opportunity for both fifth and sixth graders is the chance to join Alexander Central School on their trip to Boston, Massachusetts. To prepare for this adventure over the next several months, students will be organizing fundraisers to cover the costs. One such event is a pie sale scheduled for the end of October and the beginning of November, with delivery set before Christmas. The anticipation for this trip is high, and the students are enthusiastic about contributing to its success through these fundraising efforts.

Fifth grade has so many more exciting things to come in their learning experiences this year. I am excited to continue to watch them grow and learn more about themselves as human beings and as lifelong learners throughout the rest of the school year.



The Discovery Room

By: Mrs. Deb Welch

Grade 6 Science

Grade six scientists spent the first few weeks of school learning about the universal measuring system. Students worked towards a better understanding of the metric system. Students practiced converting within the system using a mnemonic device. Students learned about how to measure length, mass and volume using the metric system. Students were introduced to the triple beam balance and were able to practice using the balance. Students also used the graduated cylinder to volume. This graduated cylinder volume lab produced a pretty picture. The six grade scientists will be moving onto examining the characteristics of living things.

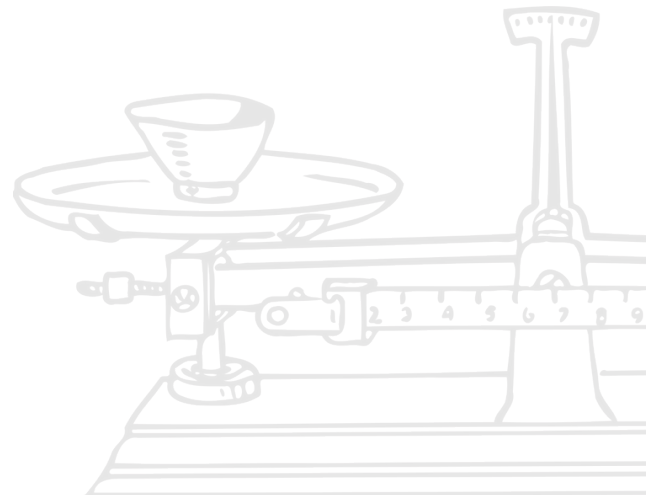

Grade 7 Life Sciences

Grade seven scientists did a review of the universal measuring system and practiced with all the equipment needed to find the mass, length or volume of an object. These scientists will next be examining how the human body heals itself. We will be using how a cut heals as a starting point for the next unit. Scientists will be examining the healing cut on a microscopic level. Students will learn about cell structure; how they reproduce; how to use a microscope to examine cells. We will then examine how the body systems interact to help heal a cut.

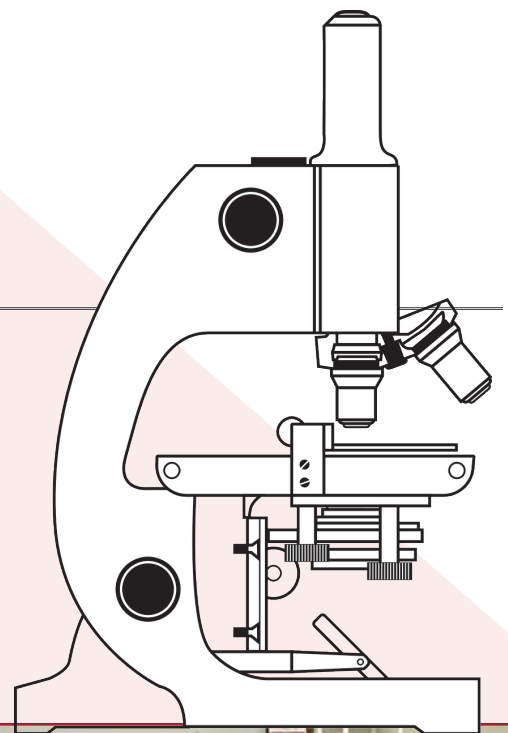

Grade 8 Physical Science

Grade eight scientists are looking into matter. What is matter? What is matter made of? What forms does matter take? The first part of the school year will be spent doing a bit of chemistry. Students will move onto the Periodic Table.

In amongst our studies we will be completing the 4 new state required labs that grade 8 students will need to have completed by the end of the year. These labs are inquiry-based and hands-on. These labs cover a great deal of material that has been covered over the last couple of years.

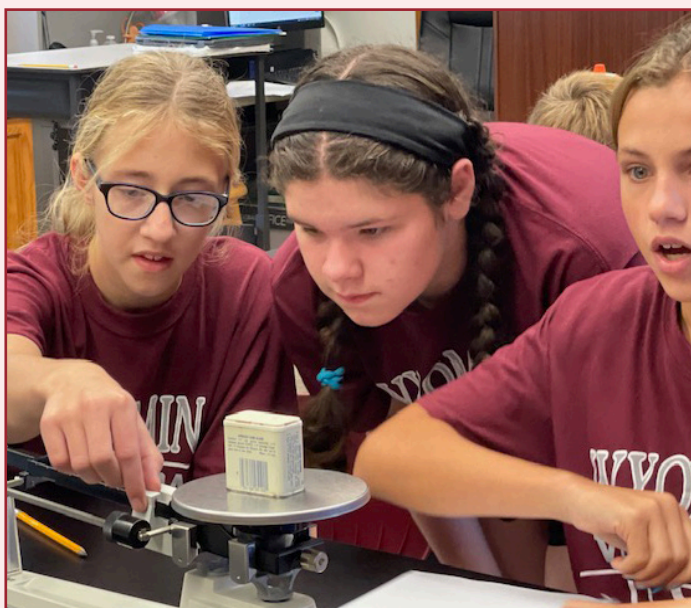

Esquina de Español = Spanish Corner

By: Mr. Pursel

¡Hola! Welcome to another year of Spanish studies. I enjoy the cooler fall weather and the start of a new school year.

During September, the Seventh and Eighth Graders worked on greetings, regular “ar” verb constructions and conversational Spanish. Currently, we are going over interrogatives. All students must learn to speak in complete Spanish sentences so they can become comfortable with Spanish dialogue.

Grades Seven and Eight are working toward mastery of the New York State World Language Standards. Students must be able to read, write, listen for understanding and speak the language in order to be successful. Final exams, which occur in June 2024, will be based on curriculum from the entire year. At this time, Grade Eight continues to review what was covered last year in order to check for retention before continuing with new material.

All Homework assignments may be found on the WCS Homework Tracker. Weekly vocabulary assignments are due on Monday for full credit. Vocabulary testing and other important content is assessed on Thursdays for both Seventh and Eighth graders. This will be our regular schedule unless there is an interruption in the calendar, like a snow day, holiday or special event. All students are encouraged to study vocabulary and go over their Review Sheets on a nightly basis and not wait until Wednesday night to cram for the Thursday assessment.

If your child is struggling with the content, please contact me as soon as possible with a phone call to discuss suggestions for improvement. I may also schedule your son/daughter to come in for extra help. At this point, everyone seems to understand my expectations for the class. I have asked all of my students to keep in mind that my courses are Junior High School classes and that we are preparing for a good transition to high school requirements.

Let’s have a good year together! Adiós.

Important NOTES from the Music Department

By: Mrs. Holly Reinhardt, Teacher

Please set aside the following dates so that you can join us as we celebrate the hard work our music students have been working on.

Our Winter Concerts are as follows:

Kindergarten – 4th Grade

Tuesday, December 5th at 6:30 pm

Middle School Band and Chorus

Thursday, December 7th at 6:30 pm

We are so excited with our new furniture!
Here is our second grade class showing the new chairs off.

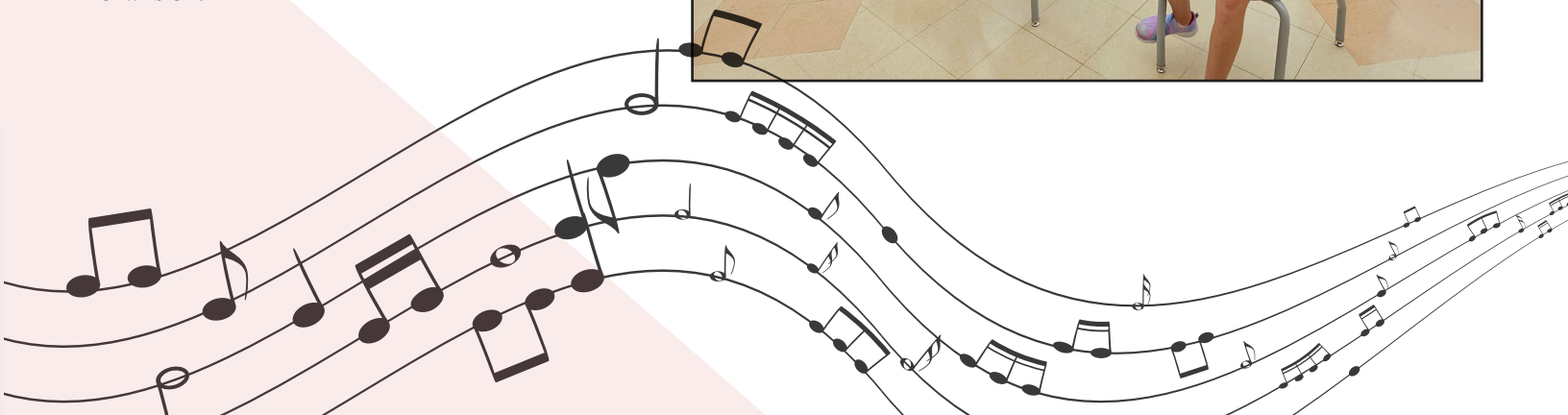

Girls Volleyball

By: Coach Hayes

The Wyoming Girls Volleyball team has had an impressive season. They have worked on improving their passes, serves, foot work, and communication skills. The team was a young team with six 7th graders that will be returning next year. We are proud to report they finished with the record of nine wins and three losses.

Next up for sports will be the girls' basketball season. That will be starting after October 23rd. That team will include most of the volleyball team so they should be exciting to watch. If you are interested, the games will be posted on the school calendar.

The boys will have their basketball season starting in December and going through January. This will be followed up by the track season where Wyoming has been dominate for 3 straight years.



Nurse's Corner

By: Maria Herman, RN – School Nurse

Know the Differences

	COVID-19	COLD	ALLERGY	FLU
Symptom / Sign				
Cough	Usually (dry)	Usually	Sometimes	Usually
Tiredness	Usually	Sometimes	Sometimes	Usually
Fever	Usually	Sometimes	Never	Usually - not always
Muscle Aches	Usually	Sometimes	Never	Usually
Sneezing	Rarely	Sometimes	Usually	
Sore throat	Usually	Usually	Rarely	Usually
Runny / stuffy nose	Usually	Usually	Usually	Usually
Diarreah	Sometimes	Never	Never	Sometimes (more commons in kids)
Nausea / vomiting	Sometimes	Never	Never	Sometimes (more commons in kids)
New loss of taste / smell	Usually	Sometimes	Sometimes	Rarely
Itchy nose, eyes, mouth, inner ear	Never		Usually	
Pink Eye	Sometimes		Sometimes	
Shortness of breath	Usually			Usually

Nurse's Corner Cont...

COVID

While Covid symptoms generally appear 2-14 days after exposure, symptoms of a common cold usually appear 1-3 days after exposure. Flu symptoms usually appear about 1-4 days after exposure. While Covid can cause shortness of breath or difficulty breathing, seasonal allergies don't usually cause these symptoms unless you have a respiratory condition such as asthma that can be triggered by pollen exposure.

RSV

RSV is another virus that has been spreading. The symptoms of RSV are: runny nose, decrease appetite, coughing, sneezing, fever, and wheezing. These symptoms usually appear in stages and not all at once. People infected with RSV usually show symptoms within 4-6 days after getting infected.

Standard precautions to reduce your risk of infection of any of the above include:

- Avoiding close contact (within 6 feet) with anyone outside your household, especially if you have a higher risk of serious illness
- Wearing a face mask in indoor public spaces
- Washing your hands often with soap and water for at least 20 seconds, or using an alcohol-based hand sanitizer that contains at least 60% alcohol
- Avoid crowded indoor spaces
- Covering your mouth and nose with your elbow or a tissue when you cough or sneeze
- Avoiding touching your eyes, nose and mouth
- Cleaning and disinfecting high-touch surfaces such as doorknobs, light switches, electronics and counters daily

Our school policy states that you should not send your child to school if he/she has:

- Fever in the past 24 hours
- Vomiting in the past 24 hours
- Diarrhea in the past 24 hours
- Sore throat
- Strep Throat (must have been taking an antibiotic for at least 24 hours before returning to school)
- Bad cold, with a very runny nose or bad cough, especially if it has kept the child awake at night
- Head lice – until your child has been treated according to the nurse or doctor's instructions
- Eyes have a yellow/green discharge
- Significant cough that makes a child uncomfortable or disrupts the class
- Honey-crusted sores around nose or mouth

If your child becomes ill at school and the teacher or school nurse feel the child is too sick to benefit from school or is contagious to other children, you will be called to come and take him/her home from school. It is essential that your child's teacher have a phone number where you can be contacted during the day and an emergency number in the event you cannot be reached. Please be sure that arrangements can be made to transport your child home from school and that childcare is available in case of illness. If your daytime or emergency phone number changes during the year, please notify your child's teacher immediately.

As a reminder, New York Education law requires a written or emailed excuse for every absence, tardy and early dismissal from school. Excuses must include the child's name, date of the absence/tardy/dismissal, reason and signature of parent/guardian.

Please feel free to call or email if you have any questions or concerns.

Maria Herman RN, School Nurse
#495-6222, ext. 106
mherman@wyoingcsd.org

Wyoming Central School District
1225 Route 19
PO Box 244
Wyoming NY 14591-0244

**NON-PROFIT
ORGANIZATION
US POSTAGE PAID
PERMIT #8
WYOMING NY
14591**

Board of Education

- Ben Chamberlain, President
- Barry True, Vice President
- Kaitlyn Bush
- Jessica Merrill
- Haley Tygart
- Rudd Wetherwax
- Nicole White

Superintendent of Schools

- Emily Herman

District Treasurer

- Joelle Stroud

www.wyomingcsd.org

Thank you

**WCS BOARD OF EDUCATION FOR YOUR
DEDICATION AND COMMITMENT
TO OUR KIDS.**

-
- Ben Chamberlain, President
 - Barry True, Vice President
 - Kaitlyn Bush
 - Jessica Merrill
 - Haley Tygart
 - Rudd Wetherwax
 - Nicole White

